

PROPELLER SPINNER MODEL	PRICE LIST (VAT non included)	DESCRIPTION OF THE OVERHAULING
Classic - E-63	400 €	<ul style="list-style-type: none"> <li>• Polishing, re-balancing, recovery of rotational plays among mechanical parts</li> <li>• Replacement of original zinc anodes</li> <li>• Replacement of all locking screws and of the central cone gear if needed</li> </ul>
Classic - E-70	460 €	
Classic - E-83	520 €	
Classic - E-100	700 €	
Classic - E-125	950 €	

In case the propeller is particularly damaged, MAX PROP® will send you a detailed free quotation before proceeding with any work.

**MAX PROP Srl**

Viale Carlo Espinasse, 101 - 20156 Milano - Italy | [www.maxprop.it](http://www.maxprop.it) | [info@maxprop.it](mailto:info@maxprop.it)  
Tel. +39 02.33.40.43.25 - Fax +39 02.38.000.791 | P.IVA 07610270154



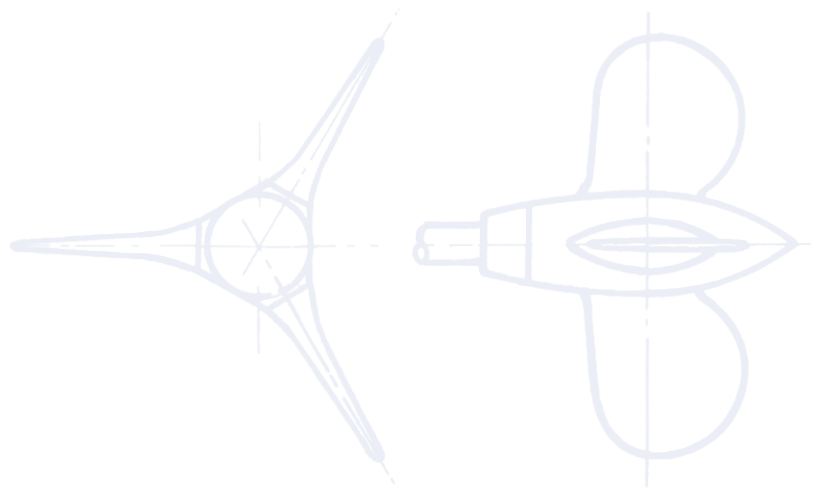

PROPELLER SPINNER MODEL	PRICE LIST (VAT non included)	DESCRIPTION OF THE OVERHAULING
Classic - E-63	430 €	<ul style="list-style-type: none"> <li>• Polishing, re-balancing, recovery of rotational plays among mechanical parts</li> <li>• Replacement of original zinc anodes</li> <li>• Replacement of all locking screws and of the central cone gear if needed</li> </ul>
Classic - E-70	500 €	
Classic - E-83	560 €	
Classic - E-100	800 €	
Classic - E-125	1200 €	
Classic - E-160	1500 €	

In case the propeller is particularly damaged, MAX PROP® will send you a detailed free quotation before proceeding with any work.

**MAX PROP Srl**

Viale Carlo Espinasse, 101 - 20156 Milano - Italy | [www.maxprop.it](http://www.maxprop.it) | [info@maxprop.it](mailto:info@maxprop.it)  
Tel. +39 02.33.40.43.25 - Fax +39 02.38.000.791 | P.IVA 07610270154



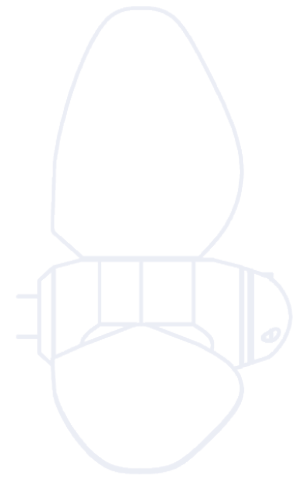

PROPELLER SPINNER MODEL	PRICE LIST (VAT non included)	DESCRIPTION OF THE OVERHAULING
Classic - E-90	750 €	<ul style="list-style-type: none"> <li>• Polishing, re-balancing, recovery of rotational plays among mechanical parts</li> <li>• Replacement of original zinc anodes</li> <li>• Replacement of all locking screws and of the central cone gear if needed</li> </ul>
Classic - E-99	800 €	

In case the propeller is particularly damaged, MAX PROP®, will send you a detailed free quotation before proceeding with any work.

**MAX PROP Srl**

Viale Carlo Espinasse, 101 - 20156 Milano - Italy | [www.maxprop.it](http://www.maxprop.it) | [info@maxprop.it](mailto:info@maxprop.it)  
Tel. +39 02.33.40.43.25 - Fax +39 02.38.000.791 | P.IVA 07610270154



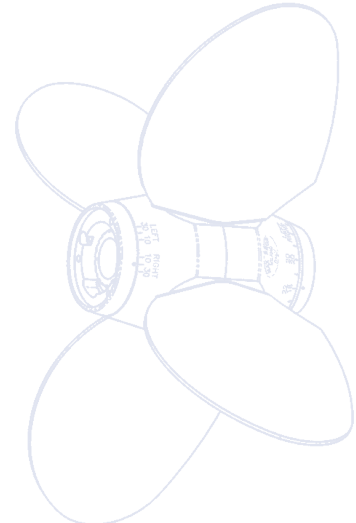
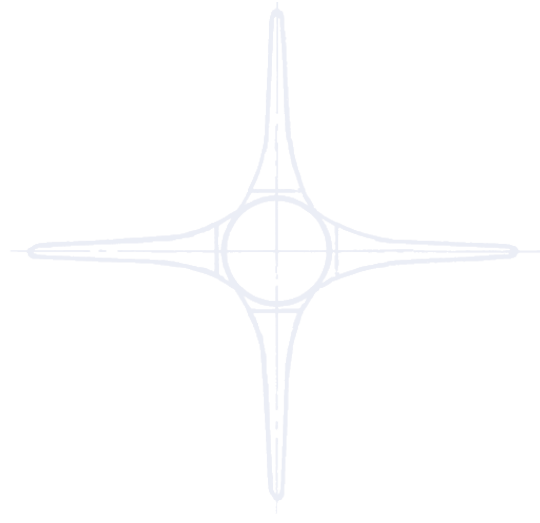
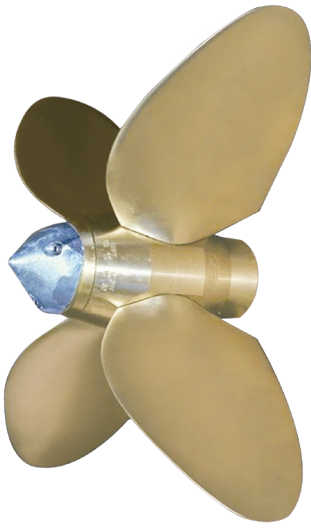

PROPELLER SPINNER MODEL	PRICE LIST (VAT non included)	DESCRIPTION OF THE OVERHAULING
Classic - E-90	750 €	<ul style="list-style-type: none"> <li>• Polishing, re-balancing, recovery of rotational plays among mechanical parts</li> <li>• Replacement of original zinc anodes</li> <li>• Replacement of all locking screws and of the central cone gear if needed</li> </ul>
Classic - E-99	800 €	
Classic - E-110	1000 €	

In case the propeller is particularly damaged, MAX PROP® will send you a detailed free quotation before proceeding with any work.

**MAX PROP Srl**

Viale Carlo Espinasse, 101 - 20156 Milano - Italy | [www.maxprop.it](http://www.maxprop.it) | [info@maxprop.it](mailto:info@maxprop.it)  
Tel. +39 02.33.40.43.25 - Fax +39 02.38.000.791 | P.IVA 07610270154





PROPELLER SPINNER MODEL	PRICE LIST (VAT non included)	DESCRIPTION OF THE OVERHAULING
Easy - E-78	400 €	<ul style="list-style-type: none"> <li>• Polishing, re-balancing, recovery of rotational plays among mechanical parts</li> <li>• Replacement of original zinc anodes</li> <li>• Replacement of all locking screws and of the central cone gear if needed</li> </ul>
Easy - E-85	450 €	
Easy - E-90	500 €	

In case the propeller is particularly damaged, MAX PROP® will send you a detailed free quotation before proceeding with any work.

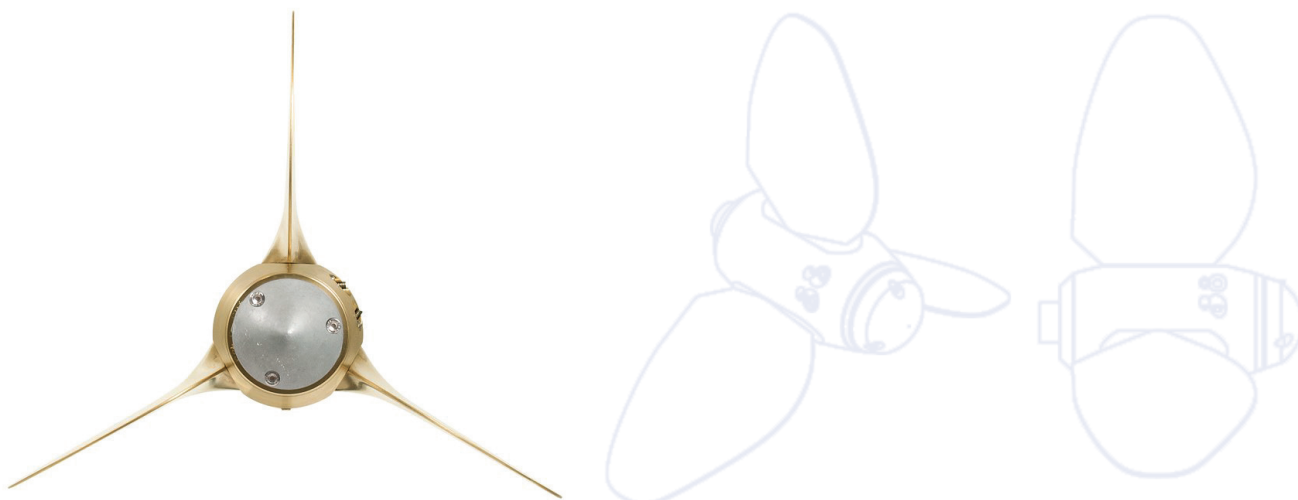

PROPELLER SPINNER MODEL	PRICE LIST (VAT non included)	DESCRIPTION OF THE OVERHAULING
Easy - E-78	400 €	<ul style="list-style-type: none"> <li>• Polishing, re-balancing, recovery of rotational plays among mechanical parts</li> <li>• Replacement of original zinc anodes</li> <li>• Replacement of all locking screws and of the central cone gear if needed</li> </ul>
Easy - E-85	450 €	
Easy - E-90	500 €	
Easy - E-99 / E-101	550 €	
Easy - E-111 / E-115	600 €	
Easy - E-120	650 €	

In case the propeller is particularly damaged, MAX PROP® will send you a detailed free quotation before proceeding with any work.

**MAX PROP Srl**

Viale Carlo Espinasse, 101 - 20156 Milano - Italy | [www.maxprop.it](http://www.maxprop.it) | [info@maxprop.it](mailto:info@maxprop.it)  
Tel. +39 02.33.40.43.25 - Fax +39 02.38.000.791 | P.IVA 07610270154



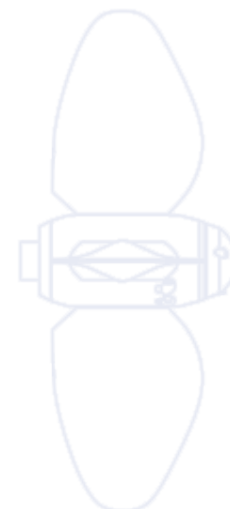

PROPELLER SPINNER MODEL	PRICE LIST (VAT non included)	DESCRIPTION OF THE OVERHAULING
Easy - E-85	475 €	<ul style="list-style-type: none"> <li>• Polishing, re-balancing, recovery of rotational plays among mechanical parts</li> <li>• Replacement of original zinc anodes</li> <li>• Replacement of all locking screws and of the central cone gear if needed</li> </ul>
Easy - E-90	525 €	
Easy - E-99 / E-101	575 €	
Easy - E-111 / E-115	625 €	
Easy - E-120	675 €	

In case the propeller is particularly damaged, MAX PROP® will send you a detailed free quotation before proceeding with any work.

**MAX PROP Srl**

Viale Carlo Espinasse, 101 - 20156 Milano - Italy | [www.maxprop.it](http://www.maxprop.it) | [info@maxprop.it](mailto:info@maxprop.it)  
Tel. +39 02.33.40.43.25 - Fax +39 02.38.000.791 | P.IVA 07610270154



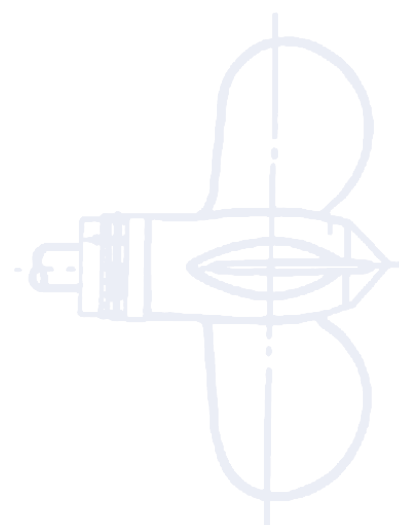
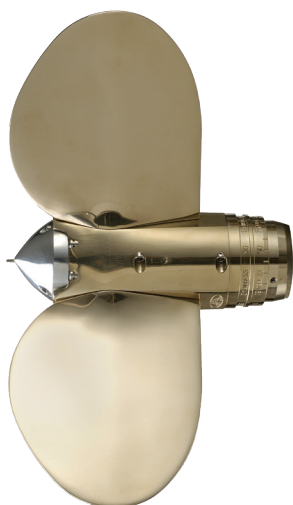

PROPELLER SPINNER MODEL	PRICE LIST (VAT non included)	DESCRIPTION OF THE OVERHAULING
Fast V.P. - E-70 Fast gen. II - E-90 / E-99	750 €	<ul style="list-style-type: none"> <li>• Polishing, re-balancing, recovery of rotational plays among mechanical parts</li> <li>• Replacement of original zinc anodes</li> <li>• Replacement of all locking screws and of the central cone gear if needed</li> </ul>
Fast V.P. - E-83 Fast gen. II - E-110	850 €	
Fast V.P. - E-100 Fast gen. II - E-126 / E-127	1100 €	

In case the propeller is particularly damaged, MAX PROP® will send you a detailed free quotation before proceeding with any work.



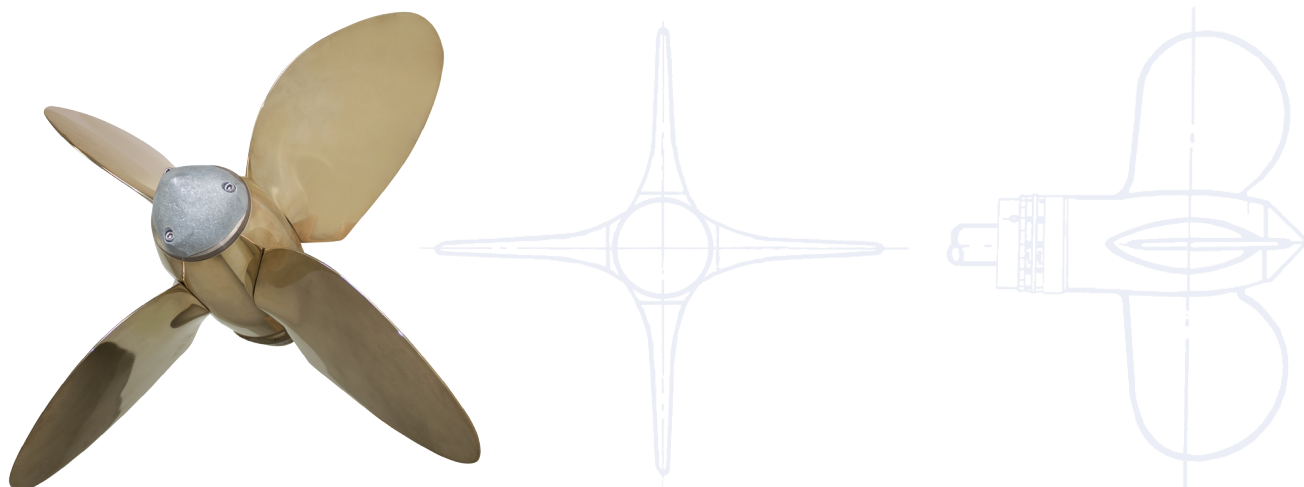

PROPELLER SPINNER MODEL	PRICE LIST (VAT non included)	DESCRIPTION OF THE OVERHAULING
Fast gen. II - E-90 / E-99	800 €	<ul style="list-style-type: none"> <li>• Polishing, re-balancing, recovery of rotational plays among mechanical parts</li> <li>• Replacement of original zinc anodes</li> <li>• Replacement of all locking screws and of the central cone gear if needed</li> </ul>
Fast gen. II - E-110	900 €	
Fast gen. II - E-126	1200 €	
Fast gen. II - E-145	1400 €	

In case the propeller is particularly damaged, MAX PROP® will send you a detailed free quotation before proceeding with any work.

**MAX PROP Srl**

Viale Carlo Espinasse, 101 - 20156 Milano - Italy | [www.maxprop.it](http://www.maxprop.it) | [info@maxprop.it](mailto:info@maxprop.it)  
Tel. +39 02.33.40.43.25 - Fax +39 02.38.000.791 | P.IVA 07610270154





PROPELLER SPINNER MODEL	PRICE LIST (VAT non included)	DESCRIPTION OF THE OVERHAULING
Whisper - E-85	520 €	<ul style="list-style-type: none"> <li>• Polishing, re-balancing, recovery of rotational plays among mechanical parts</li> <li>• Replacement of original zinc anodes</li> <li>• Replacement of all locking screws and of the central cone gear if needed</li> </ul>
Whisper - E-99 / E-101	650 €	
Whisper - E-110 / E-111	700 €	
Whisper - E-120	750 €	
Whisper - E-126 / E-127 E-129 / E-130	850 €	
Whisper - E-144 / E-148 E-150	1300 €	
Whisper - E-161 / E-170	1600 €	
Whisper - E-190	2000 €	

In case the propeller is particularly damaged, MAX PROP® will send you a detailed free quotation before proceeding with any work.

**MAX PROP Srl**

Viale Carlo Espinasse, 101 - 20156 Milano - Italy | [www.maxprop.it](http://www.maxprop.it) | [info@maxprop.it](mailto:info@maxprop.it)  
Tel. +39 02.33.40.43.25 - Fax +39 02.38.000.791 | P.IVA 07610270154



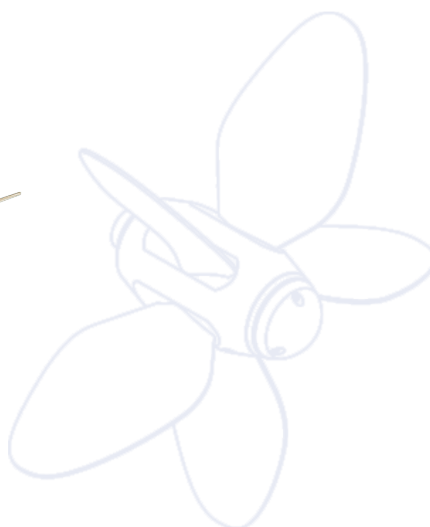

PROPELLER SPINNER MODEL	PRICE LIST (VAT non included)	DESCRIPTION OF THE OVERHAULING
Boomerang - E-101	680 €	<ul style="list-style-type: none"> <li>• Polishing, re-balancing, recovery of rotational plays among mechanical parts</li> <li>• Replacement of original zinc anodes</li> <li>• Replacement of all locking screws and of the central cone gear if needed</li> </ul>
Boomerang - E-111	730 €	
Boomerang- E-120	780 €	
Boomerang - E-129	880 €	
Boomerang - E-144	1330 €	
Boomerang - E-161	1630 €	
Boomerang - E-190	2030 €	

In case the propeller is particularly damaged, MAX PROP® will send you a detailed free quotation before proceeding with any work.

## MAX PROP Srl

Viale Carlo Espinasse, 101 - 20156 Milano - Italy | [www.maxprop.it](http://www.maxprop.it) | [info@maxprop.it](mailto:info@maxprop.it)  
Tel. +39 02.33.40.43.25 - Fax +39 02.38.000.791 | P.IVA 07610270154

